

Produce machine quality welds and cuts in any plane or position with a portable drive on magnetic track.

The versatile GO-FER III Kits make straight line welding and cutting more efficient and economical.



Bug-O Systems

Affordable Track Cutting and
Welding Systems.



GO-FER III OXY-FUEL KIT / GOF-3250-OX

The **GO-FER III Oxy-Fuel Kit** is used for straight line cuts and weld preparation beveling. The kit comes complete with the exception of a torch. The Bug-O Torch Holder will accept any standard 1-3/8" (35 mm) diameter machine torch with a 32 pitch gear rack. The Quick-Action Gas Manifold mounted to the rear of the machine is used as a strain reliever for the torch and also gives the operator the ability to turn on and off the pre-heat gases without having to readjust the gas flow of the torch.

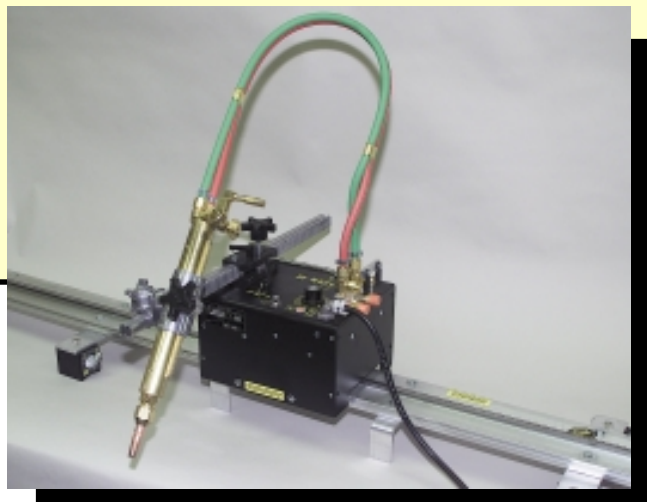
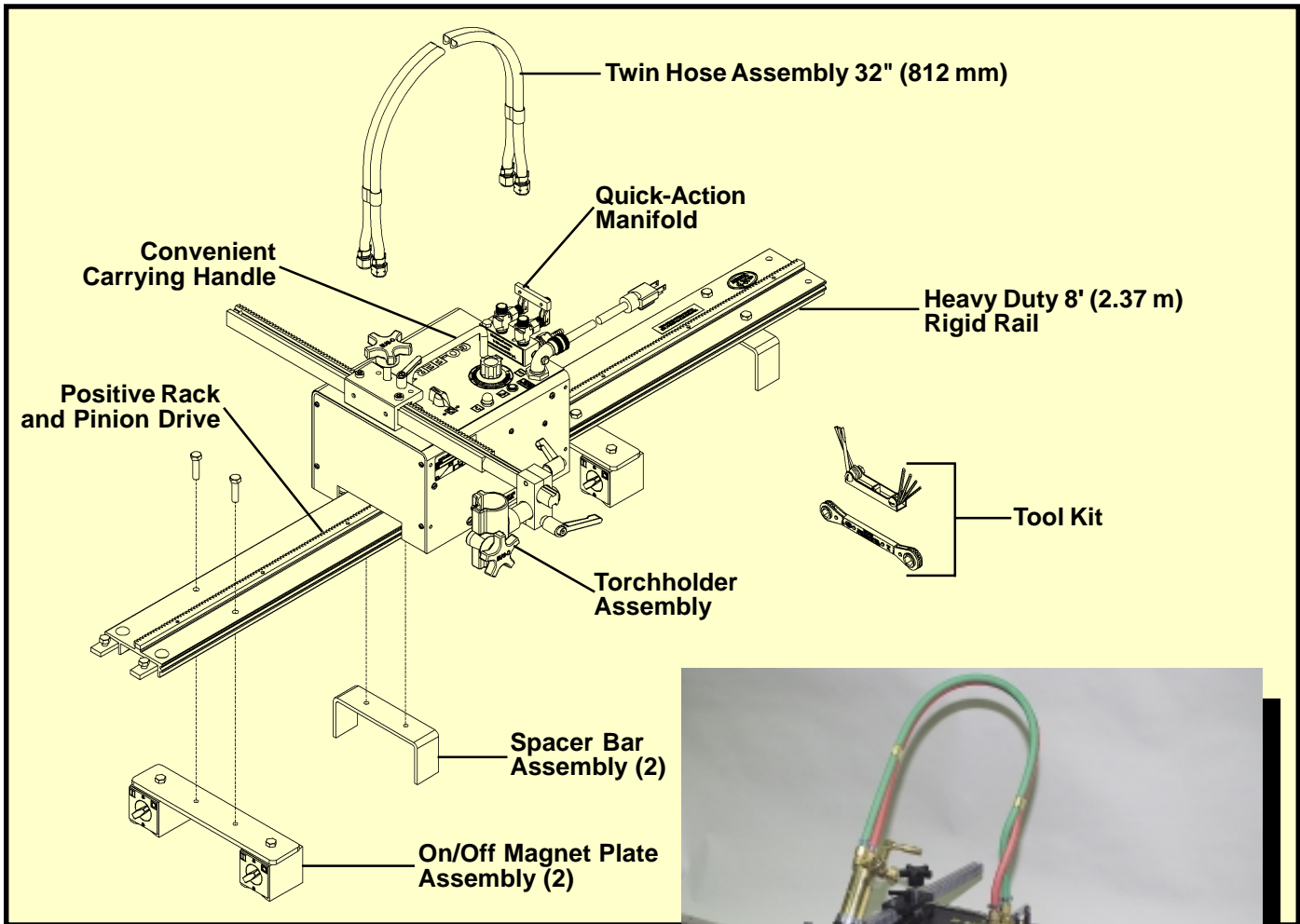

Each GOF-3250-OX kit includes the following:

- 1 ARR-1080 Heavy Duty Rigid Rail 93.50" (2.37 m)
- 2 ARM-2500 On/Off Magnet Plate Assembly
- 2 ARM-2505 Spacer Bar Assembly
- 1 GOF-3240-OX GO-FER III Drive Unit w/Dynamic braking 8-100 ipm (203-2640 mm/min)

Each GOF-3240-OX Drive Unit includes the following sub assemblies:

- 1 GOF-3025 2-Hose Manifold
- 1 CIR-1010-3 Twin Hose Assembly
- 1 BUG-5451 Rackholder with Short Handle
- 1 PAN-1015 Rack 22.62" (574 mm)
- 1 BUG-5462 Right Angle Clamp
- 1 BUG-5188 Torchholder Assembly
- 1 BUG-9444 Tool Kit

GOF-3252-OX Same as above except with 240 VAC GO-FER III GOF-3242-OX

GOF-3254-OX Same as above except with 42 VAC GO-FER III GOF-3244-OX

Net Weight of Kit: 39 lbs. (17.7 kg)

Shipping Weight of Kit: 50 lbs. (22.7 kg)



GO-FER III WELDING KIT / GOF-3250-WD

The **GO-Fer III Welding Kit** is an economical straight-line welding travel carriage. The all position Fits-All Clamp will accept and accommodate any hand held welding gun and allow the operator to position the torch at any angle they desire. The racking group allows for in process torch adjustment for the vertical and horizontal plane. A built in torch trigger contactor allows the operator to activate the wire feeder from a switch on the top of the Drive unit.

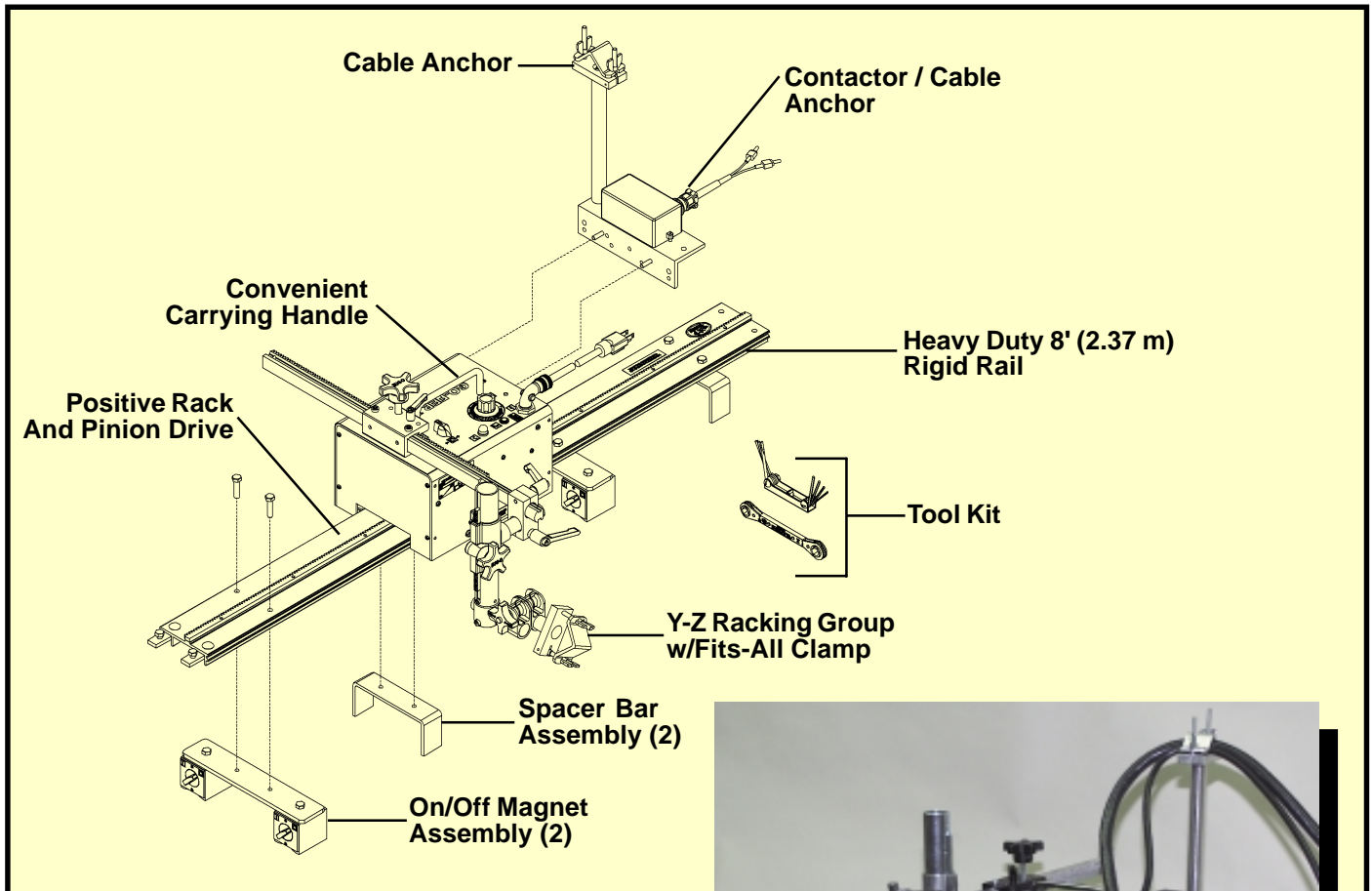

Each GOF-3250-WD kit includes the following:

- 1 ARR-1080 Heavy Duty Rigid Rail 93.50" (2.37 m)
- 2 ARM-2500 On/Off Magnet Plate Assembly
- 2 ARM-2505 Spacer Bar Assembly
- 1 GOF-3240-WD GO-FER III Drive Unit w/Dynamic braking 2-50 ipm (50-1270 mm/min)

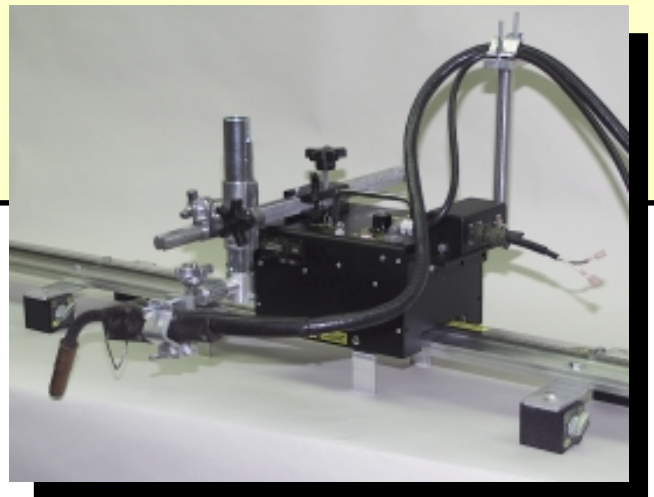

Each GOF-3240-WD Drive Unit includes the following sub assemblies:

- 1 BUG-5485 Contactor / Cable Anchor
- 1 BUG-5451 Rackholder with Short Handle
- 1 PAN-1015 Rack 22.62" (574 mm)
- 1 BUG-5462 Right Angle Clamp
- 1 BUG-5188 Torchholder Assembly
- 1 BUG-9444 Tool Kit
- 1 BUG-5166-8 8" Tube Rack w/Clamp
- 1 BUG-2708 Fits-All Clamp
- 1 BUG-9180-4 Rod 7/8" x 4"
- 1 CON-1020 Swivel Clamp

GOF-3252-WD

Same as above except with 240 VAC GO-FER III GOF-3242-WD

GOF-3254-WD

Same as above except with 42 VAC GO-FER III GOF-3244-WD

Net Weight of Kit:

39 lbs. (17.7 kg)

Shipping Weight of Kit:

50 lbs. (22.7 kg)



GO-FER III PLASMA KIT / GOF-3250-PL

The **GO-Fer III Plasma Kit** is specifically designed to work in conjunction with a plasma machine. It's travel speed of 8-100 inches per minute (203-2640 mm/min) and it's direct rack and pinion drive make it ideal as an all position portable cutting machine for a plasma torch. The torch holder will accept any standard 1-3/8" (35 mm) diameter machine torch that has a 32 pitch gear rack. A built in trigger contactor for initiating the cut makes the GO-FER a convenient self contained package.

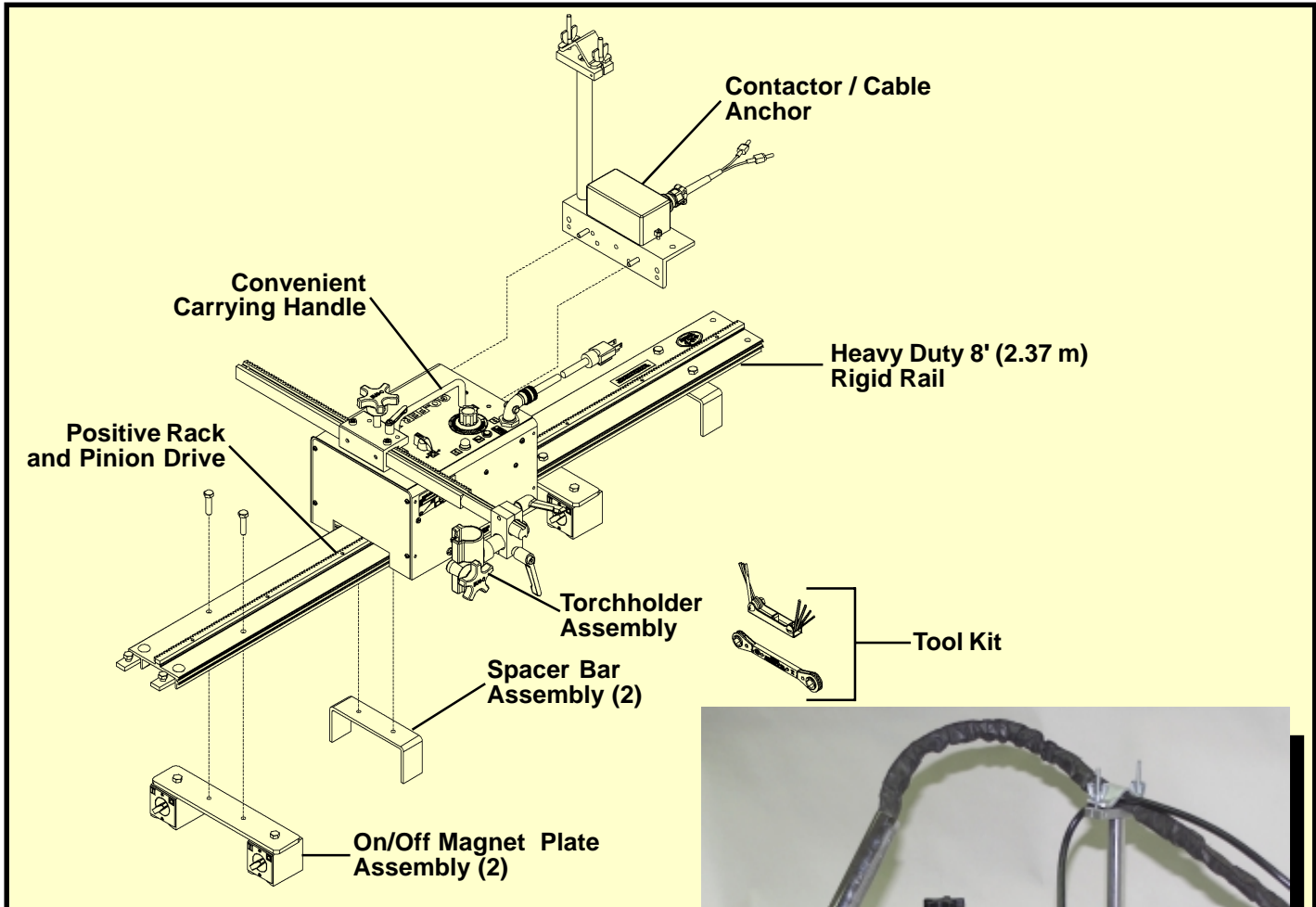

NOTE: A shielded gun and cable assembly must be used to reduce hi-frequency interference.

Each GOF-3250-PL Plasma kit includes the following:

- 1 ARR-1080 Heavy Duty Rigid Rail 93.50" (2.37 m)
- 2 ARM-2500 On/Off Magnet Plate Assembly
- 2 ARM-2505 Spacer Bar Assembly
- 1 GOF-3240-PL GO-FER III Drive Unit w/Dynamic braking 8-100 ipm (203-2640 mm/min)

Each GOF-3240-PL Drive Unit includes the following sub assemblies:

- 1 BUG-5485 Contactor / Cable Anchor
- 1 BUG-5451 Rackholder with Short Handle
- 1 PAN-1015 Rack 22.62" (574 mm)
- 1 BUG-5462 Right Angle Clamp
- 1 BUG-5188 Torchholder Assembly
- 1 BUG-9444 Tool Kit



GOF-3252-PL Same as above except with 240 VAC GO-FER III GOF-3242-PL

GOF-3254-PL Same as above except with 42 VAC GO-FER III GOF-3244-PL

Net Weight of Kit: 39 lbs. (17.7 kg)

Shipping Weight of Kit: 50 lbs. (22.7 kg)



GO-FER III Accessories

GOF-3142 Radius Cutting Attachment:

Enables GO-FER III to be quickly changed from a straight line to a circle-cutting machine.

Size Range: 8" to 96"
(203 mm to 2438 mm) diameter.

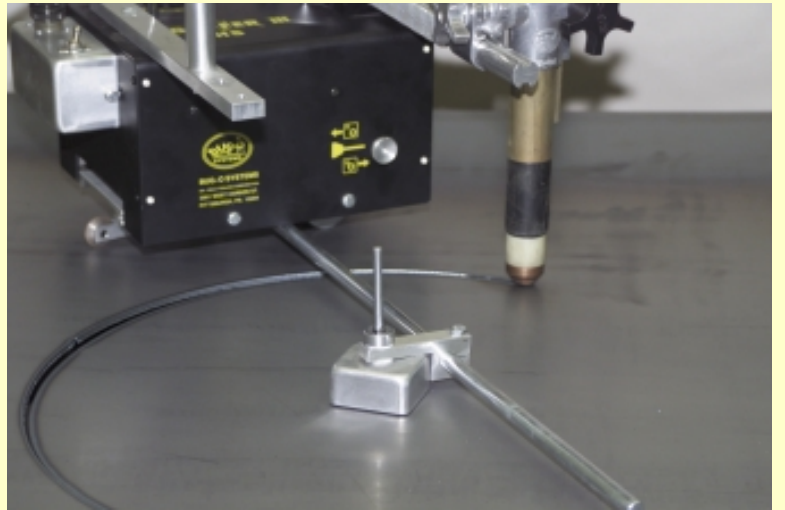
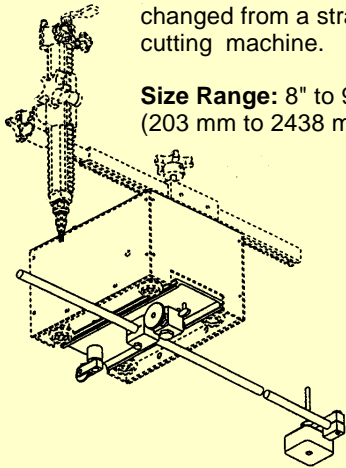

Panograph Assemblies

Panographs are spring-loaded devices that maintain torch stand-off and compensate for plate surface irregularities.

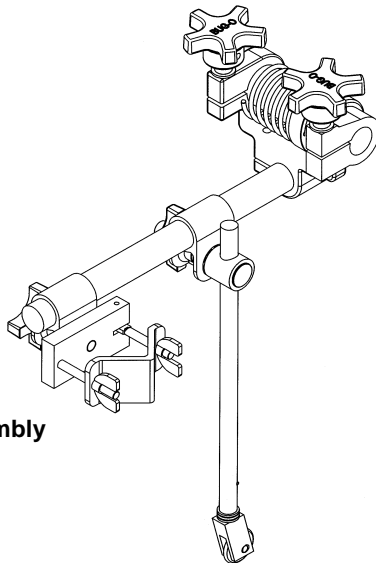

PAN-1007
Welding Panograph Assembly

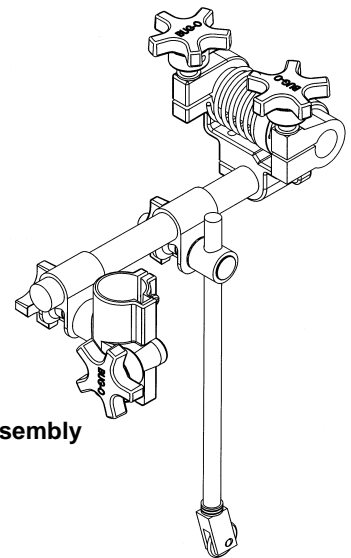

PAN-1010
Cutting Panograph Assembly

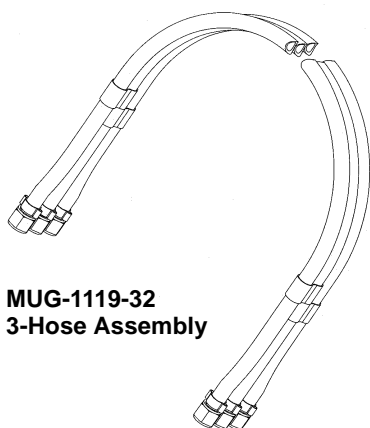

MUG-1119-32
3-Hose Assembly

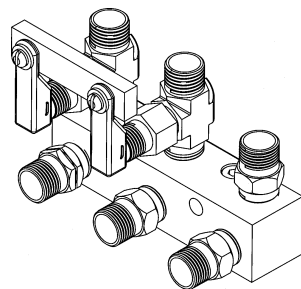

BUG-9898
3-Hose Quick-Acting Manifold

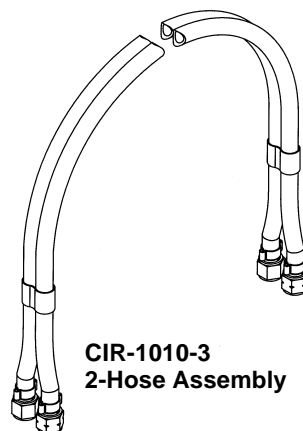

CIR-1010-3
2-Hose Assembly

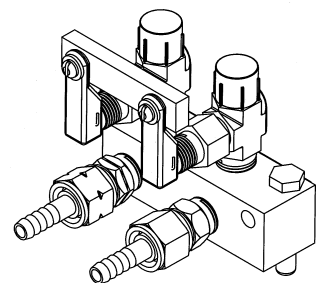

GOF-3025
2-Hose Quick-Acting Manifold



GO-FER III Accessories

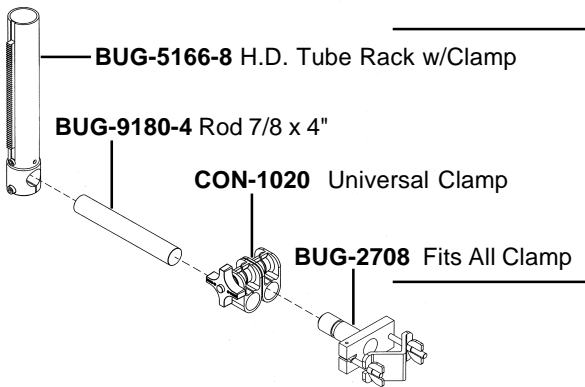

The addition of these 4 items provides a vertical racking motion for hand held guns.

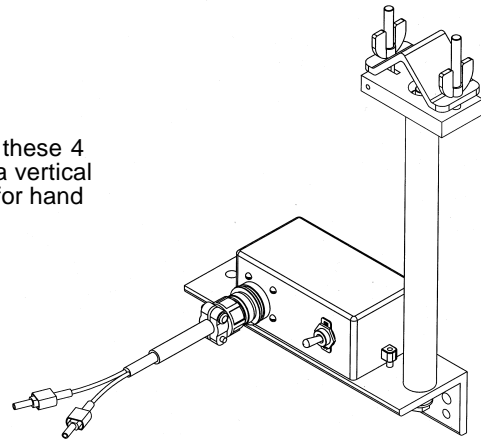

BUG-5485 Contactor/Cable Anchor:
Provides built-in contactor switch to control plasma or welding process. The Cable Anchor provides strain relief for all cables.

Rails & Attachments

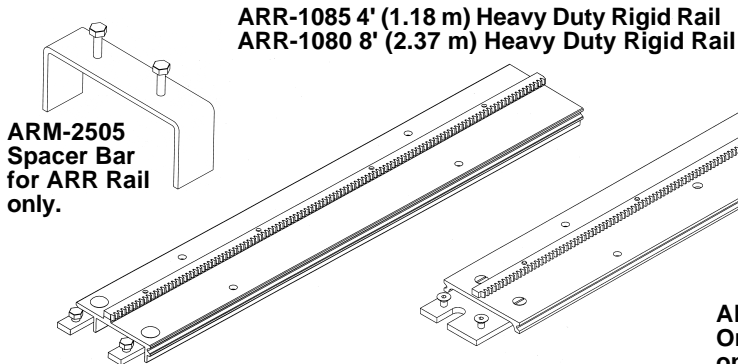

ARM-2505
Spacer Bar
for ARR Rail
only.

ARR-1085 4' (1.18 m) Heavy Duty Rigid Rail
ARR-1080 8' (2.37 m) Heavy Duty Rigid Rail

AFR-3000 Semi-Flex Rail can be bent inside or outside to a minimum radius of 15' (5.0 m) or 30' (10.0 m) diameter without permanent deformation.

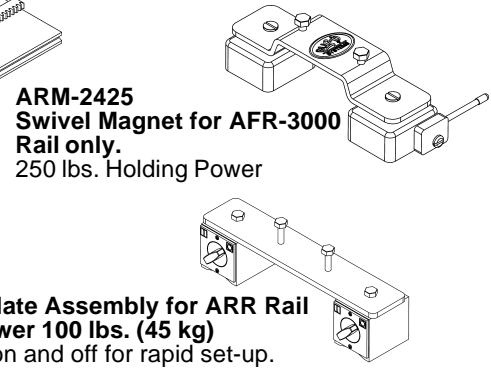

ARM-2425
Swivel Magnet for AFR-3000
Rail only.
250 lbs. Holding Power

ARM-2500
On-Off Magnet Plate Assembly for ARR Rail
only. Holding power 100 lbs. (45 kg)
Can be switched on and off for rapid set-up.

Vacuum Systems For Non-Ferrous Metals

Standard Vacuum Support Kits:

- ARV-1080 Vacuum Kit**
For ARR-1080 & AFR-3000 Rails.
- ARV-1085 Vacuum Kit**
For ARR-1085 Rails.

Custom systems are required for Bent Rail.

- ARV-2020 120 Volt/50-60 Hz**
 - ARV-2030 220 Volt/50-60 Hz**
- The ARV-2020 (ARV-2030) Vacuum Pump Kit is recommended for use with a maximum of four (4) pieces of rail, or sixteen (16) vacuum bars.

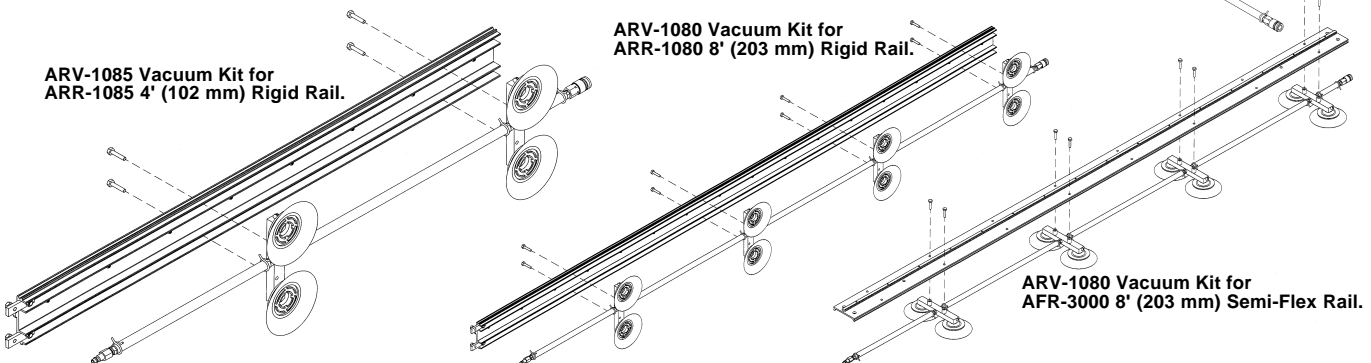

ARV-1085 Vacuum Kit for
ARR-1085 4' (102 mm) Rigid Rail.

ARV-1080 Vacuum Kit for
ARR-1080 8' (203 mm) Rigid Rail.

ARV-1080 Vacuum Kit for
AFR-3000 8' (203 mm) Semi-Flex Rail.

